

Kidde Fire Systems

ECS™ 360 Cylinder Component Datasheet



Cylinder and Valve Assemblies, 900 lb. (368 L) Capacity with HFC-227ea Agent

Effective: November 2023
K-90-9044 Rev BB

FEATURES

- *Large Capacity Agent Cylinder*
- *3-Inch Discharge Valve*
- *Optional Liquid Level Indicator*
- *Optional Low-Level Switch (P/N 06-118263-001)*
- *Can be filled with Reclaimed/Refined HFC-227ea agent*
- *FM Approved*
- *UL Listed*
- *TC Approved*
- *RoHS Compliant*

DESCRIPTION

Kidde Fire Systems ECS™ 360 System 900 lb. Agent Cylinders store suppression agent super-pressurized with dry nitrogen to 360 PSIG at 70°F (2.48 Mpa at 21°C). The cylinders are painted red and are equipped with a 3-inch pressure differential valve, pressure gauge, optional liquid level indicator and optional low-pressure switch assembly. The safety burst disc is located on the cylinder shoulder.

OPERATION

The agent storage container discharges when the actuation assembly operates, causing the pressure differential valve to open. All of the Kidde Fire Systems actuators may be used to actuate the 900 lb. cylinder. The only exception is the 82-486500-010, which is not compatible with this cylinder valve.

INSTALLATION

The container is installed in a vertical position with the valve assembly pointing up. Interconnection to discharge piping is 3-inch NPT. Interconnection can be via a 3-inch flex hose (P/N 06-118225-001) or via a suitably pressure rated groove style fitting.

The container is secured in place by a mounting bracket (P/N 06-236125-001), which must be fixed to a solid wall or strut assembly. After the container is securely mounted, it is connected to discharge piping per the directions in the Design, Installation, Operation and Maintenance Manual (P/N 06-236115-001).

For marine applications, 2 straps may be required, consult the local authority having jurisdiction. For 900 lb. (368 L) agent cylinders in marine applications, a cradle is required between the cylinder and the unistrut or bulk-head for support.

An optional cylinder supervisory pressure switch (P/N 06-118262-001) can be installed on the cylinder valve in the field if required.

MAINTENANCE

According to NFPA standards, the following inspection and/or maintenance procedure must be scheduled as listed below and performed upon the occurrence of any event which might affect the reliability of the system.



QUARTERLY INSPECTION

1. Check the pressure gauges of each agent storage container. If the pressure gauge indicates a loss in pressure of 10% or more, then it shall be recharged or replaced. Pressure varies with temperature, and this must be taken into account when checking the pressure gauge. In the range of 55°F to 85°F (13°C to 29°C) the change is approximately 3 PSI per degree F (0.2 bar per degree C).
2. Check all components, including supporting hardware, and tighten, repair or replace as required.
3. Replace any component if at all in doubt of its ability to perform properly.

SEMI-ANNUAL INSPECTION

Qualified personnel should determine the amount of agent in all containers. The optional liquid level indicator may be used to measure agent supply and compare it to the original net weight which is marked on the container label. If the measured net weight is less than 95% of the original charged weight the container should be recharged or replaced.

Inspect all piping, fittings and nozzles for looseness, dirt or other damage. All outlet piping must be clean and free of dirt, chips, fillings and other foreign material that may cause the system to become inoperative or ineffective at the time of discharge.

SPECIFICATIONS

Part Number	90-100900-001 90-100901-001	
	imperial	metric
Fill range	390-900 lb.	178-408 kg
Height	70 in.	1789 mm
Diameter	24 in.	610 mm
Internal Volume	13.0 cu. ft.	0.368 cu. m
Empty Weight	505 lb.	229 kg
Temperature Range	32oF to 130oF	0oC to 54oC
Safety Relief		
Burst Range	800 to 975 PSIG	5.5 to 6.7 Mpa
Construction Specification	DOT 4BW-500	DOT 4BW-50

ORDER INFORMATION

Part Number	Description
90-100900-001	900 lb. (368 L) agent cylinder without LLI
90-100901-001	900 lb. (368 L) agent cylinder with LLI

DIMENSIONS

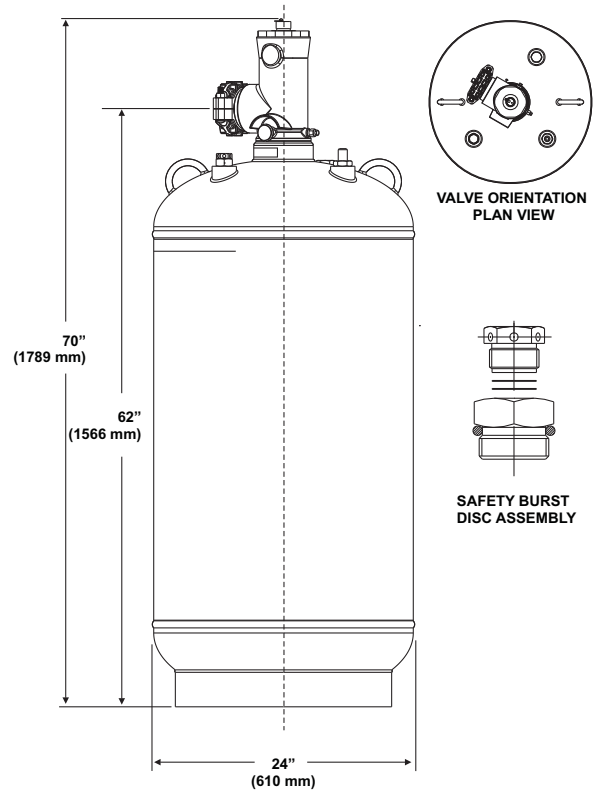

ACCESSORIES

Part Number	Description
06-118225-001	3-inch stainless steel flexible hose
06-118058-001	3-inch swing check valve
06-236125-001	Cylinder bracket
06-118263-001	Cylinder supervisory pressure switch

MANUALS

Manual	P/N
Kidde Fire Systems ECS™ 360 System with HFC-227ea Agent	06-236115-001
Kidde Fire Systems ECS™ 360 Marine System with HFC227ea Agent	06-236225-001

EXPORT INFORMATION (USA)

Jurisdiction: EAR
 Classification: EAR99
 This document contains technical data subject to the EAR.

All trademarks are the property of their respective owners.

This literature is provided for informational purposes only. KIDDE-FENWAL, INC. believes this data to be accurate, but it is published and presented without any guarantee or warranty whatsoever. KIDDE-FENWAL, INC. assumes no responsibility for the product's suitability for a particular application. The fire suppression system design, installation, maintenance, service and troubleshooting must be performed by trained, authorized Kidde Fire Systems distributors for the product to work correctly. If you need more information on this product, or if you have a particular problem or question, contact: KIDDE-FENWAL, INC., Ashland, MA 01721 USA, Telephone: (508) 881-2000.